



eSystem

Hint: Model specific installation guides can be found at www.scottoiler.com



www.scottoiler.com



technical@scottoiler.com



+44 (0)141 955 1100

Technical Support



YouTube



flickr

Visit our pages on Facebook, YouTube, Twitter and flickr.

Scottoiler Ltd. 2 Riverside, Milngavie, Glasgow, G62 6PL, UK.

version 3.1

1. Display Mounting Choose the fitting best suited to your motorcycle.

Sticky fastener (part 4) fitting for any flat surface.



Hint: Ensure all surfaces are clean & degreased before attaching fastener.



Bracket Mount. Fits to any existing M5/M6 bolt. Fit display unit to bracket (part 5) using M3 screws (part 16).

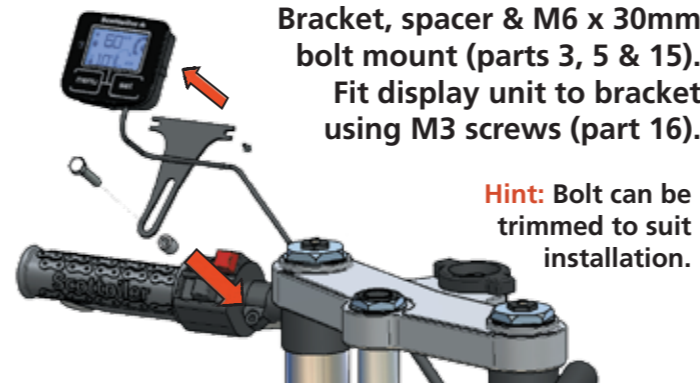

Bracket, spacer & M6 x 30mm bolt mount (parts 3, 5 & 15). Fit display unit to bracket using M3 screws (part 16).

Hint: Bolt can be trimmed to suit installation.

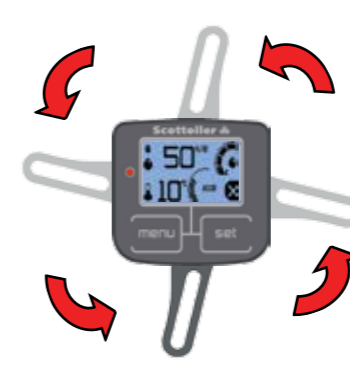

Bracket (part 5) can be rotated through 360° to allow four fitting options.



Avoid hot exhaust and engine components

2. Dispenser Assembly Choose the fitting best suited to your motorcycle. Some models of bike require adapter kits available free of charge from Scottoil.

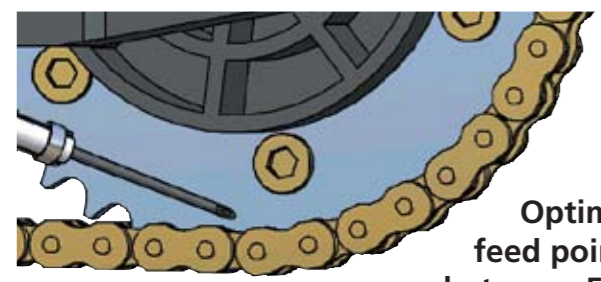

Optimum feed point is between 5 & 7 o'clock on the face of the rear sprocket.

Hint: Nib should be lightly touching sprocket with slash cut facing out.

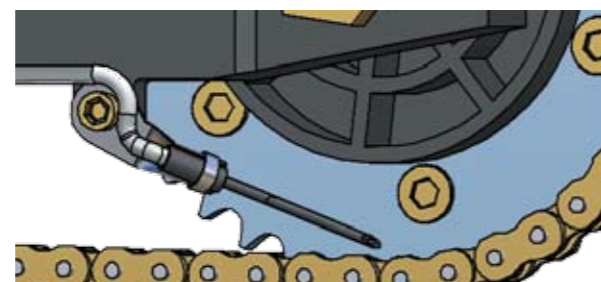

Bobbin mount (parts 14, 17 & 13/18)

Hint: The rigid black PVC tubing on the dispenser assembly (part 14) can be trimmed to achieve a neater install.



Spindle mount (parts 14, 17 & 13/18)

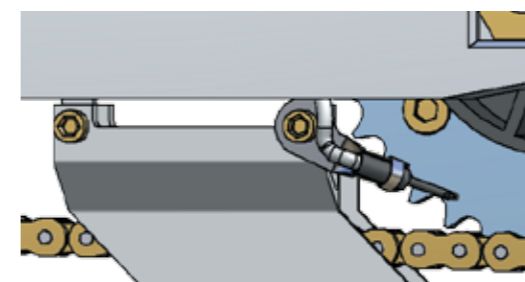

Sprocket guard (parts 14, 17 & 13/18)

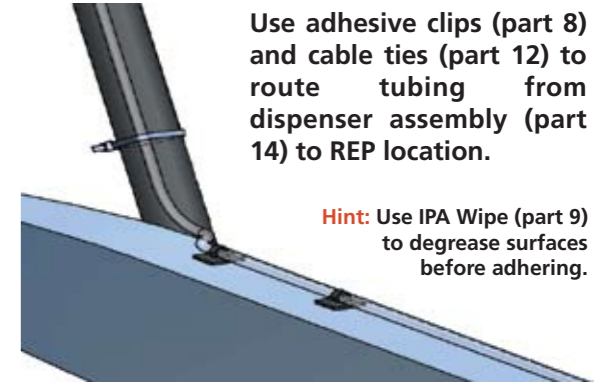

Use adhesive clips (part 8) and cable ties (part 12) to route tubing from dispenser assembly (part 14) to REP location.

Hint: Use IPA Wipe (part 9) to degrease surfaces before adhering.

3. Reservoir Electronic Pump (REP)

Mount REP with nozzle inclined upwards and filling hole accessible.

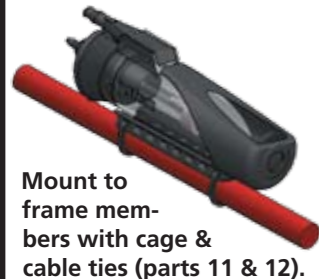

Mount to frame members with cage & cable ties (parts 11 & 12).

A hole can be drilled anywhere on the spine which allows mounting with a bolt.

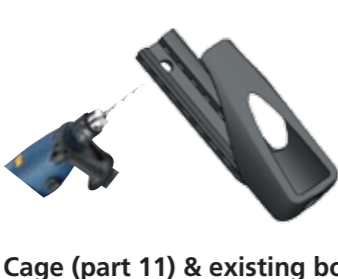

Cage (part 11) & existing bolt

Attach check valve (part 6) to dispenser tubing and ensure tubing reaches REP but **do not** connect check valve to REP at this stage.



Do not connect check valve to REP until after priming!

4. Power Connections

Note: connections **MUST** be made directly to battery terminals to provide an uninterrupted power supply, or the system **WILL NOT** function correctly.

Locate bike battery.

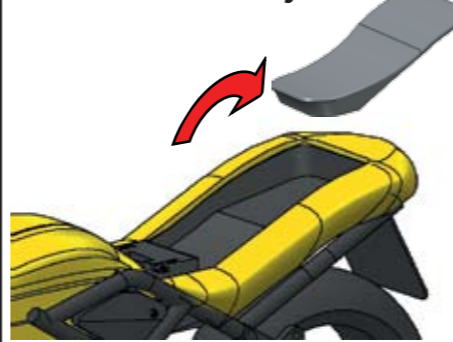

Connect wiring loom (part 1) to battery.

Attach **RED** wire to the +ve terminal and attach **BLACK** wire to the -ve terminal.

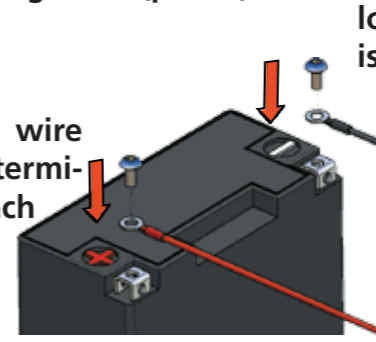

Connect REP (part 7) to wiring loom (part 1). Ensure that the clip is aligned properly.

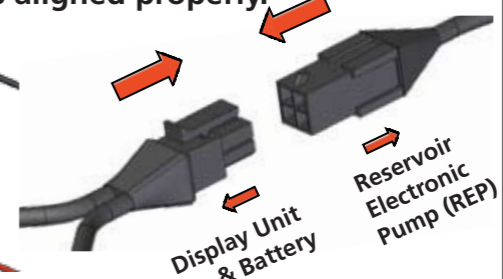

Display Unit & Battery Reservoir Electronic Pump (REP)

5. REP Filling

Fill REP using bottle & spout (part 19).



Attach breather assembly (part 2) to REP (part 7).

6. Initial Setup

A Press and hold 'menu' button to manually start the eSystem. The 'Driving Screen' shows with information required during general usage.

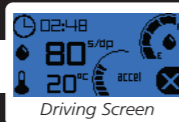

B Press 'menu' and the additional reservoir screen is displayed. If you have a Lube Tube select this, if you have an HCR select this. If no extra capacity, leave as None.



C Press 'menu' until you reach the Reservoir Menu. Press 'set' once to set the bar at 100%. Do this every time you refill the reservoir.



D Press 'menu' until you reach the Prime Menu. Press 'set' to initiate a 60 second prime cycle. Repeat this step until oil starts dripping from your REP spigot.



Note: It is important to carry out this step **before** the check valve is attached.

Attach the check valve (part 6) to the REP nozzle ensuring arrow is pointing in direction of flow. Repeat step D until oil drips from dispenser nib. This can take several cycles depending on tubing length.



E It is **vital** for effective performance that the check valve is present in the oil dispenser line.

F Top up your REP with oil using the bottle and spout (part 19). Then re-set the 'Reservoir' menu to ensure it reads 100%. This will ensure the oil level gauge remain accurate.



G Press 'menu' until you reach the Calibration Menu. Ensure your bike is upright and steady. Press 'set' to calibrate the unit. (**Note:** The engine should **NOT** be running).



H There is one further menu option, the Oiling Threshold menu. This is set to '6' as default. It is not necessary to adjust this setting initially, however it may be used to make the oiler more or less sensitive to acceleration.



I Finally, set the clock screen. Press 'menu' until you reach the clock screen, then press 'set' to change the time. To move to the next digit press for 3 seconds then release.

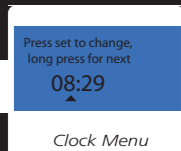

J Press 'menu' until you reach the 'Driving Screen'. Press 'set' repeatedly until the flow rate is at your desired level. Recommended rate is 50 - 60 s/dp.

